



Most Widely Accepted and Trusted

ICC-ES Report

ESR-1369

ICC-ES | (800) 423-6587 | (562) 699-0543 | www.icc-es.org

Reissued 05/2016
This report is subject to renewal 05/2017.

DIVISION: 06 00 00—WOOD, PLASTICS AND COMPOSITES

SECTION: 06 53 00—PLASTIC DECKING

SECTION: 06 63 00—PLASTIC RAILINGS

REPORT HOLDER:

GREEN BAY DECKING, LLC

**1518 SOUTH BROADWAY STREET
GREEN BAY, WISCONSIN 54304**

EVALUATION SUBJECT:

GEODECK™ COMPOSITE DECKING AND GUARDRAIL SYSTEMS



Look for the trusted marks of Conformity!

“2014 Recipient of Prestigious Western States Seismic Policy Council (WSSPC) Award in Excellence”



A Subsidiary of

ICC-ES Evaluation Reports are not to be construed as representing aesthetics or any other attributes not specifically addressed, nor are they to be construed as an endorsement of the subject of the report or a recommendation for its use. There is no warranty by ICC Evaluation Service, LLC, express or implied, as to any finding or other matter in this report, or as to any product covered by the report.



ICC-ES Evaluation Report

ESR-1369

Reissued May 2016

This report is subject to renewal May 2017.

www.icc-es.org | (800) 423-6587 | (562) 699-0543

A Subsidiary of the International Code Council®

**DIVISION: 06 00 00—WOOD, PLASTICS AND
COMPOSITES**
Section: 06 53 00—Plastic Decking
Section: 06 63 00—Plastic Railings
REPORT HOLDER:

GREEN BAY DECKING, LLC
1518 SOUTH BROADWAY STREET
GREEN BAY, WISCONSIN 54304
(920) 435-1526
www.geodeck.com
GeoDeck-OurService@greenbaydecking.com

EVALUATION SUBJECT:
**GEODECK™ COMPOSITE DECKING AND GUARDRAIL
SYSTEMS**
1.0 EVALUATION SCOPE
1.1 Compliance with the following codes:

- 2012, 2009 and 2006 *International Building Code*® (IBC)
- 2012, 2009 and 2006 *International Residential Code*® (IRC)
- 2013 *Abu Dhabi International Building Code* (ADIBC)[†]
- 1997 *Uniform Building Code*™ (UBC)

[†]The ADIBC is based on the 2009 IBC. 2009 IBC code sections referenced in this report are the same sections in the ADIBC.

Properties evaluated:

- Structural
- Durability
- Surface-burning characteristics

**1.2 Evaluation to the following green code(s) and/or
standards:**

- 2013 California Green Building Standards Code (CALGreen), Title 24, Part 11
- 2012 and 2008 ICC 700 *National Green Building Standard*™ (ICC 700-2012 and ICC 700-2008)

Attributes verified:

- See Section 3.1

2.0 USES

The GEODECK™ Composite Decking Systems evaluated in this report is are limited to exterior use as a deck board for balconies, porches, stair treads and decks of Type V-B (IBC) and Type V-N (UBC) construction and structures

constructed in accordance with the IRC. The GEODECK™ Composite Decking System includes the GEODECK™, and Classic GEODECK™, TerrainDeck™ and DuxxBak™ Composite Decking.

GEODECK™ Composite Guardrail described in this report is limited to exterior use as guards for balconies, porches, and decks. The product described in this report is used in exterior applications in buildings of Type V-B (IBC) construction and other types of construction in applications where untreated wood is permitted by Section 1406.3 (IBC) or buildings constructed in accordance with the IRC.

3.0 DESCRIPTION
3.1 General:

GEODECK™, Classic GEODECK™, TerrainDeck™ and DuxxBak™ Composite Decking are wood thermoplastic composite lumber (WTCL) products consisting of high-density polyethylene, rice hulls, and a mineral filler with additives and color. The product specifications are listed in the approved quality control manual. The GEODECK™ and Classic GEODECK™ Composite Decking System components are manufactured by an extrusion process in four colors: cedar, mahogany, driftwood, and walnut. The TerrainDeck™ deck boards are manufactured by an extrusion process in two colors; Rustic Red and Copper Canyon. The DuxxBak™ deck boards are manufactured by an extrusion process in the colors of Mahogany, Cedar, Driftwood, Walnut, Copper Canyon and Rustic Red.

The attributes of the composite decking have been verified as conforming to the provisions of (i) CALGreen Section A5.406.1.2 for reduced maintenance; (ii) ICC 700-2012 Sections 602.1.6 and 11.602.1.6 for termite-resistant materials and Sections 601.7, 11.601.7, and 12.1(A).601.7 for site-applied finishing materials; and (iii) ICC 700-2008 Section 602.8 for termite-resistant materials and Section 601.7 for site-applied finishing materials. Note that decisions on compliance for those areas rest with the user of this report. The user is advised of the project-specific provisions that may be contingent upon meeting specific conditions, and the verification of those conditions is outside the scope of this report. These codes or standards often provide supplemental information as guidance. See Section 5.11 for limitations on termite-resistance use.

3.2 Deck Board:

The Classic GEODECK™ Composite Decking is manufactured in three hollow profiles in 12-, 16- and 20-foot (3658, 4877, and 6096 mm) lengths. The three profiles are Classic GEODECK™ Decking 5/4 by 6 Traditional Board, Classic GEODECK™ Decking 5/4 by 6 Tongue and Groove Board and Classic GEODECK™ 2x8 Heavy Duty Commercial Plank.

The GEODECK™ Composite Decking is manufactured in two hollow profiles in 12-, 16-, and 20-foot (3658, 4877, and 6096 mm) lengths. The two profiles are GEODECK™ Decking $\frac{5}{4}$ by 6 Traditional S4S and GEODECK™ Decking $\frac{5}{4}$ by 6 Tongue and Groove Board. The walking surface for both designs of the GEODECK™ Decking System is wire brushed to provide a coarse surface.

Each of the Classic GEODECK™ and GEODECK™ profiles are also manufactured as the TerrainDeck™ decking system. The walking surface of the TerrainDeck™ Decking System is wire-brushed and lasered to provide a coarse surface.

The Classic GEODECK™ and TerrainDeck™ Decking $\frac{5}{4}$ by 6 Traditional Board (profile ID number 1015 and 5015) is 5.50 inches (140 mm) wide and 1.27 inches (32 mm) thick. The wall thickness of the profile is 0.26 inch (6.6 mm). The decking profile has four ribbed cell openings created by three stiffeners which are 0.20 inch (5.1 mm) thick. See Figure 1 for the profile of this decking system component. The Classic GEODECK™ and TerrainDeck™ traditional board are also used for stair treads.

GEODECK™ and TerrainDeck™ Decking $\frac{5}{4}$ by 6 Traditional S4S Board (profile ID number 1012 and 5012) is 5.50 inches (140 mm) wide and 1.27 inches (32 mm) thick. The wall thickness of the profile is 0.23 inch (5.8 mm) on top and 0.16 inch (4.1 mm) on the bottom. The decking profile has four ribbed cell openings created by three stiffeners which are 0.128 inch (3.3 mm) thick. See Figure 4 for the profile of this decking system component. The GEODECK™ and TerrainDeck™ traditional board is also used for stair treads.

The Classic GEODECK™ and TerrainDeck™ Decking $\frac{5}{4}$ by 6 Tongue and Groove Board (profile ID number 1016 and 5016) is 5.50 inches (140 mm) wide and 1.27 inches (32 mm) thick. The wall thickness of the profile is 0.26 inch (6.6 mm). The decking profile has three ribbed cell openings created by two stiffeners which are each 0.235 inch (6 mm) thick. The decking board profile is shaped to interlock with adjacent decking boards. See Figure 2 for the profile of this decking system component.

GEODECK™ and TerrainDeck™ Decking $\frac{5}{4}$ by 6 Tongue and Groove Board (profile ID number 1013 and 5013) is 5.50 inches (140 mm) wide and 1.27 inch (32 mm) thick. The wall thickness of the profile is 0.21 inch (5.3 mm) on the top and 0.160 inch (4.1 mm) on the bottom. The decking profile has three ribbed cell openings created by two stiffeners which are each 0.128 inch (3.3 mm) thick. The decking board profile is shaped to interlock with adjacent decking boards. See Figure 5 for the profile of this decking system component.

Classic GEODECK™ and TerrainDeck™ 2 by 8 Heavy Duty Commercial Decking Plank (profile ID number 1017 and 5017) is 8.10 inches (206 mm) wide and 1.55 inches (39 mm) thick. The wall thickness of the profile is 0.26 inch (6.6 mm). The decking profile has five ribbed cell openings created by four stiffeners which are each 0.20 inch (5.1 mm) thick. See Figure 3 for the profile of this decking system component.

The DuxxBak™ Composite Decking is manufactured in a hollow profile with an interlocking leg on both sides and comes in 12-, 16-, and 20-foot (3658, 4877 and 6096 mm) lengths.

The DuxxBak™ Decking $\frac{5}{4}$ by 6 (profile ID number 1080 and 5080) is 5.75 inches (146 mm) wide [7.3 inches (185 mm) overall, including the interlocking legs] and

1.27 inches (32 mm) thick. The wall thickness of the profile is 0.26 inch (6.6 mm). The decking profile has three ribbed cell openings created by three stiffeners which are 0.2 inch (5.1 mm) thick and two interlocking legs. See Figure 6 for the profile for this decking system component.

3.3 Guards:

GEODECK™ Composite Guardrail is a guard consisting of post sleeves, caps, top rails with aluminum inserts, bottom rails, balusters, and a bottom-rail support block. The GEODECK™ Composite Guardrail system components are made from the same material as the deck boards except for the aluminum insert, which is made from aluminum alloy 6061-T6. The minimum yield and tensile strength, and minimum thickness, of the aluminum inserts are specified in the approved quality control manual.

The height of the railing assembly is 36 inches or 42 inches (914 or 1067 mm) above the walking surface. Each post is covered with a 4-inch-by-4-inch composite post sleeve. The top rail has an oval shape. The oval-shaped rail is 3.36 inches (85 mm) wide at the top and has a depth of 2.00 inches (51 mm) and a wall thickness of 0.36 inch (9.14 mm). Both top and bottom rails are available in 6- and 8-foot lengths (1.83 and 2.44 m). See Figure 7 for the profile of the rail system components.

The balusters are hollow square extruded pickets. The pickets are $1\frac{3}{4}$ inches (44.4 mm) square, and have a wall thickness of $\frac{1}{4}$ inch. When the pickets are installed in the rails, there is a clear space of approximately 3.37 inches (86 mm) between pickets for 8-foot-long (2.44 m) assemblies and 3.49 inches (87 mm) between pickets for 6-foot long (1.83 m) assemblies.

The post sleeves are 4.3 inches (109 mm) square and have a wall thickness of 0.26 inch (6.6 mm). See Figure 6 for dimensioned profiles of the post sleeves, top and bottom rails, top rail aluminum inserts, and balusters. The mounting brackets are made from steel conforming to ASTM A1008 CS Type B with a plastic cover. The 8-foot and 6-foot (2.44 m and 1.83 m) rail systems utilize intermediate bottom rail supports. The 8-foot (2.44 m) rail system has three supports located at quarter points. The 6-foot (1.83 m) rail system has two supports located at third points.

3.4 Durability:

When subjected to weathering, insect attack and other decaying elements, GEODECK™ decking system and guardrail material are equivalent in durability to preservative-treated or naturally durable lumber. Accordingly, it is permitted to be used as an alternative to preservative-treated or naturally durable lumber on exterior decks, porches and balconies, stair treads and guardrail. The GEODECK™ decking systems and guardrail material have been evaluated for structural capacity when exposed to temperatures from -20°F (-29°C) to 125°F (52°C).

3.5 Surface-burning Characteristics:

When tested in accordance with ASTM E84, GEODECK™ decking and guardrail systems have a flame-spread index of no greater than 200.

4.0 DESIGN AND INSTALLATION

4.1 General:

Installation of the GEODECK™ Composite Decking Systems and the GEODECK™ Composite Guardrail System must comply with this report and the

manufacturer's published installation instructions. The manufacturer's published installation instructions must be available at the jobsite at all times during installation.

4.2 Deck Boards:

4.2.1 Design:

4.2.1.1 Deck Boards: The GEODECK™ Composite Decking Systems, when used as deck boards, has an allowable capacity (span ratings) as shown in Table 1.

4.2.1.2 Deck Boards Used as Stair Treads: GEODECK™, Classic GEODECK™ and TerrainDeck™ Composite Decking, when used as stair treads, are satisfactory to resist the code-prescribed concentrated load of 300 lbf (1.34 kN) when installed at a maximum center-to-center spacing of the supporting construction as shown in Table 2.

4.2.2 Installation: Installation of GEODECK™ Composite Decking Systems must comply with this report and the manufacturer's published installation instructions. The manufacturer's published installation instructions must be available at the jobsite at all times during installation. When the manufacturer's published installation instructions differ from this report, this report governs.

GEODECK™, Classic GEODECK™ and TerrainDeck™ Composite Decking Tongue and Groove Boards must be installed by one of the following methods: (1) a No. 7 by 2.25 inch long (57.2 mm) stainless or a No. 8 or No. 9 by 2.5 inch long (63.5 mm) stainless or coated trim head screw; or (2) an 8d by 2.5 inch long (63.5 mm) stainless or coated ring shank nail. Apply one fastener per joist, through the tongue, at a 55-60 degree angle.

GEODECK™, Classic GEODECK™ and TerrainDeck™ Composite Decking Traditional Boards must be installed by one of the following methods: (1) a No. 7 by 2.25-inch-long (57.2 mm) stainless or a No. 8 or No. 9 by 2.5-inch-long (63.5 mm) stainless or coated deck screw or trim head screw; or (2) an 8d, 2.5-inch-long (63.5 mm) stainless or coated ring shank nail. Apply two fasteners per joist, fastened through the face of the board.

Heavy Duty Commercial and TerrainDeck™ Decking Plank must be installed by one of the following methods: (1) No. 10 by 3.0-inch-long (76 mm) stainless steel or coated deck screw or (2) No. 10d, 3.0-inch-long (76 mm) stainless steel or coated ring shank nail. Apply 3 fasteners per joist, fastened through the face of the board.

DuxxBak™ must be installed by one of the following methods: (1) No. 7 by 1.25-inch-long (31.8 mm) stainless or No. 8 or No. 9 by 2.5-inch-long (63.5 mm) stainless or coated trim head screw; or (2) 8d by 2.5-inch-long (63.5 mm) stainless or coated ring shank nail. Apply one fastener per joist, fastened through the interlocking leg of the board.

4.3 Guards:

4.3.1 General: Refer to Figure 6 for component cross sections and guard assemblies.

4.3.2 Design: The GEODECK™ Composite Guardrail is satisfactory to resist the loads specified in Section 1607.7.1 of the IBC and Table R301.5 of the IRC, when installed at a maximum clear span spacing, as noted in Table 3. When the railing is supported on one or both ends by the supporting construction, the maximum distance must be measured from edge-of-post to edge-of-structure or from edge-of-structure to edge-of-structure.

4.3.3 Installation: The guardrail system is a 6-foot-long or 8-foot-long assembly in which the top and bottom rails

are hollow oval members. The assembly has aluminum inserts in the top rail only. The rails are attached to a post and sleeve, rigid column or building wall with metal brackets secured with four No. 8 by 2-inch-long stainless steel wood screws. The rail end slides over the bracket and is secured to the bracket with one No. 8 by 1/2-inch-long, self-drilling, stainless steel sheet metal screws. The pickets are 1 3/4 inches square and are spaced 3.37 inches apart (open clear space) for the 8-foot rail system and 3.49 inches apart for the 6-foot rail system. The top and bottom rails are routed to accept the pickets with no further attachment.

5.0 CONDITIONS OF USE

The GEODECK™ Composite Decking and Guardrail Systems described in this report comply with, or are suitable alternatives to what is specified in, those codes listed in Section 1.0 of this report, subject to the following conditions:

5.1 This product must be limited to exterior use as a deck board for balconies, porches, decks, stair treads and similar appendages of Type V-B (IBC) and Type V-N (UBC) construction and structures constructed in accordance with the IRC.

GEODECK™ Composite Guardrail described in this report is limited to exterior use as guards for balconies, porches, and decks. The product described in this report is used in exterior applications in buildings of Type V-B (IBC) construction and other types of construction in applications where untreated wood is permitted by Section 1406.3 (IBC) or buildings constructed in accordance with the IRC.

5.2 Installation must comply with this report, the manufacturer's published instructions and the applicable code. When the manufacturer's published installation instructions differ from this report, this report governs.

5.3 The use of the GEODECK™ Composite Decking Systems as a component of a fire-resistance-rated assembly is outside the scope of this report.

5.4 Only those fasteners and fastener configurations described in this report have been evaluated for the installation of the GEODECK™ Composite Decking and Guardrail Systems. The compatibility of the fasteners with the supporting construction, including chemically treated wood, is outside the scope of this report.

5.5 GEODECK™ Composite Decking and Guardrail Systems must be directly fastened to supporting construction. Where required by the code official, engineering calculations and construction documents consistent with this report must be submitted for approval. The calculations must verify that the supporting construction complies with the applicable building code requirements and is adequate to resist the loads imparted upon it from the products and systems discussed in this report. The documents must contain details of the attachment to the supporting structure consistent with the requirements of this report. The documents must be prepared by a registered design professional where required by the statutes of the jurisdiction in which the project is to be constructed.

5.6 Adjustment factors outlined in the AF&PA National Design Standard and applicable codes must not apply to the allowable capacity and maximum spans of the decking system.

- 5.7 The use of wood posts, with or without post sleeves; are, outside the scope of this report.
- 5.8 The top rail component of the GEODECK™ Composite Guardrail System must not be permitted to be used as a handrail for stairways or ramps.
- 5.9 The use of a corner rail connection that is connected to a rail post is outside the scope of this report.
- 5.10 GEODECK™ Composite Decking and Guardrail System components are produced in Green Bay, Wisconsin, under a quality control program with inspections by ICC-ES.
- 5.11 GEODECK™ Composite Decking and Guardrail Systems have not been evaluated for use in areas subject to Formosan termite attack.

6.0 EVIDENCE SUBMITTED

Data in accordance with the ICC-ES Acceptance Criteria for Deck Board Span Ratings and Guardrail Systems (Guards and Handrails) (AC174), dated January 2012.

7.0 IDENTIFICATION

The GEODECK™ Composite Decking described in this report must be identified on each individual piece by a laser engraving bearing the manufacturer’s name Green Bay Decking, LLC), the product type, the allowable span and allowable load for the deck boards and stair treads, and the evaluation report number (ESR-1369).

The GEODECK™ Composite Guardrail described in this report is identified on the rails by a laser engraving bearing the manufacturer’s name (Green Bay Decking, LLC), product type, allowable span, production date and time, and the evaluation report number (ESR-1369). The balusters are identified by a stamp bearing the profile number (1004) and the production date.

TABLE 1—DECK BOARD SPAN RATING

PRODUCT NAME	MAXIMUM SPAN ¹ (inches)	ALLOWABLE CAPACITY ² (lbf/ft ²)
Classic GEODECK™ and TerrainDeck™ Decking 5/4 by 6 Traditional Board (Hollow)	16	100
Classic GEODECK™ and TerrainDeck™ Decking 5/4 by 6 Tongue & Groove Board (Hollow)	16	100
Classic GEODECK™ and TerrainDeck™ Decking 5/4 by 6 Traditional Board (Hollow)	24 ³	60
Classic GEODECK™ and TerrainDeck™ Decking 5/4 by 6 Tongue & Groove Board (Hollow)	24 ³	60
Classic GEODECK™ and TerrainDeck™ Decking 2 by 8 Heavy Duty Commercial Plank (Hollow)	28	100
GEODECK™ and TerrainDeck™ Decking 5/4 by 6 Traditional S4S Board (Hollow)	16	100
GEODECK™ and TerrainDeck™ Decking 5/4 by 6 Tongue & Groove Board (Hollow)	16	100
GEODECK™ and TerrainDeck™ Decking 5/4 by 6 Traditional S4S Board (Hollow)	21 ³	60
GEODECK™ and TerrainDeck™ Decking 5/4 by 6 Tongue & Groove Board (Hollow)	21 ³	60
DuxxBak™ Decking 5/4 by 6 (Hollow)	16	100
DuxxBak™ Decking 5/4 by 6 (Hollow)	24 ³	60

For SI: 1 inch = 25.4 mm; 1 lbf/ft² = 47.9 Pa.

¹Maximum span is measured center-to-center of the supporting construction.

²Maximum allowable capacity is adjusted for durability. No further increases are permitted.

³Allowable span when limited to use in Group R occupancy groups under the IBC and buildings constructed under the IRC.

TABLE 2—MAXIMUM STAIR TREAD SPANS²

DECK BOARDS USED AS STAIR TREADS	MAXIMUM SPAN (inches) ¹
Classic GEODECK™ and TerrainDeck™ Decking 5/4 by 6 Traditional Board (Hollow)	16
Classic GEODECK™ and TerrainDeck™ Decking 5/4 by 6 Tongue & Groove Board (Hollow)	16
Classic GEODECK™ and TerrainDeck™ Decking 2 by 8 Heavy Duty Commercial Plank (Hollow)	16
GEODECK™ and TerrainDeck™ Decking 5/4 by 6 Traditional Board (Hollow)	12
GEODECK™ and TerrainDeck™ Decking 5/4 by 6 Tongue & Groove Board (Hollow)	12

For SI: 1 inch = 25.4 mm; 1 lbf/ft² = 47.9 Pa.

¹Maximum span is measured center-to-center of the supporting construction.

²Based on a minimum 2-span installation.

TABLE 3—MAXIMUM GUARDRAIL SYSTEM SPANS¹

PRODUCT NAME/COMPONENT	APPLICABLE BUILDING CODE ^{2,5}		MAXIMUM SPAN ^{3,4} (ft-in)
	IBC	IRC	
GEODECK™ Composite Guardrail	Yes	Yes	6 - 0
GEODECK™ Composite Guardrail	Yes	Yes	8 - 0

For SI: 1 inch = 25.4 mm; 1 ft = 305 mm.

¹The ability of the supporting construction to resist the reactionary loads must be justified to the satisfaction of the code official.

²Indicates compliance with the respective building codes

³Maximum span is measured from edge-of-post to edge-of-post.

⁴Maximum allowable span has been adjusted for durability. No further increases are permitted.

⁵The minimum height of the top rail is 42 inches for the IBC (Section 1013.2) and 36 inches for the IRC (Section R312).

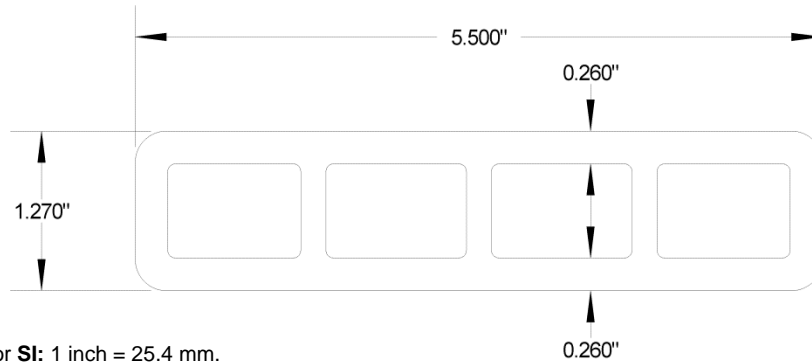

FIGURE 1—CLASSIC GEODECK™ AND TERRAINDECK™ DECKING ⁵/₄ BY 6 TRADITIONAL BOARD (HOLLOW)

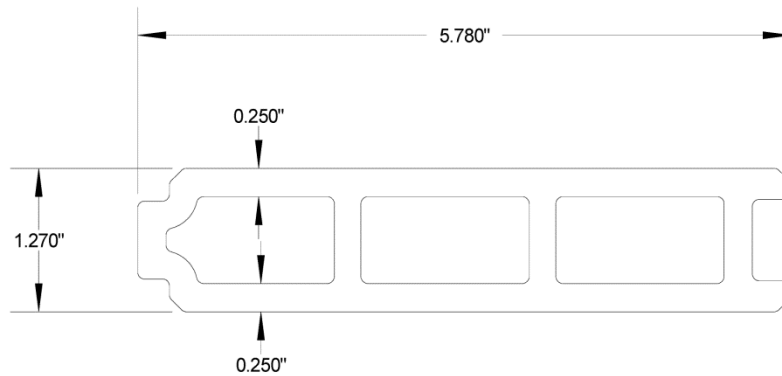

FIGURE 2—CLASSIC GEODECK™ AND TERRAINDECK™ DECKING ⁵/₄ BY 6 TONGUE & GROOVE BOARD (HOLLOW)

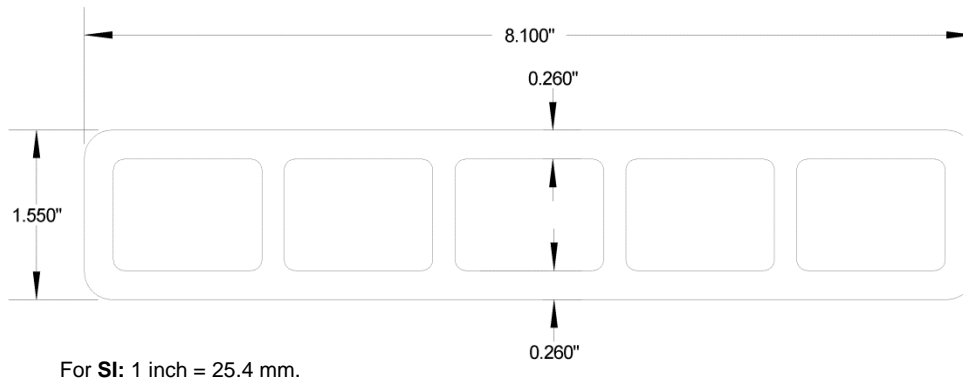

FIGURE 3—CLASSIC GEODECK™ AND TERRAINDECK™ DECKING 2 BY 8 HEAVY DUTY COMMERCIAL PLANK (HOLLOW)

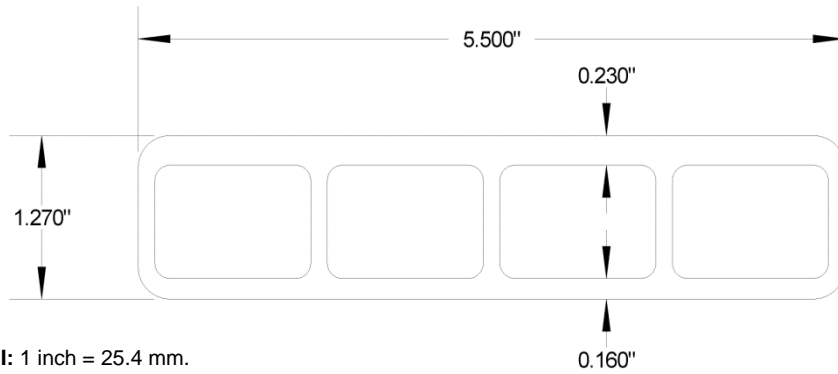

FIGURE 4—GEODECK™ AND TERRAINDECK™ DECKING 5/4 BY 6 TRADITIONAL S4S BOARD (HOLLOW)

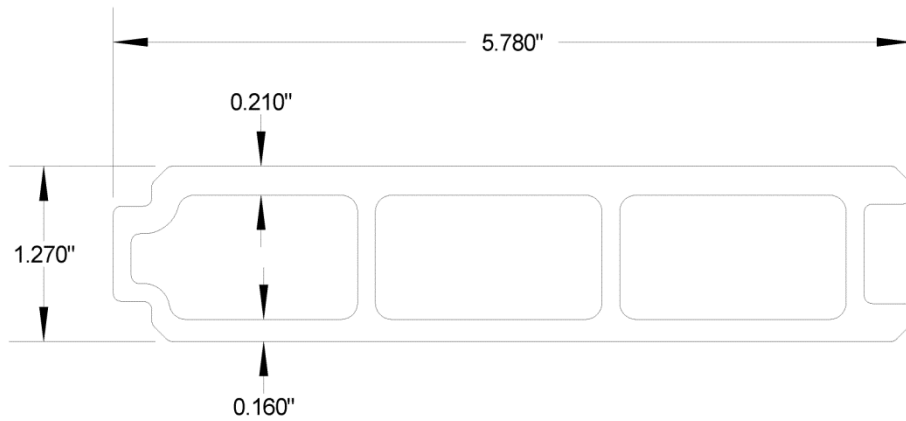

FIGURE 5—GEODECK™ AND TERRAINDECK™ DECKING 5/4 BY 6 TONGUE & GROOVE BOARD (HOLLOW)

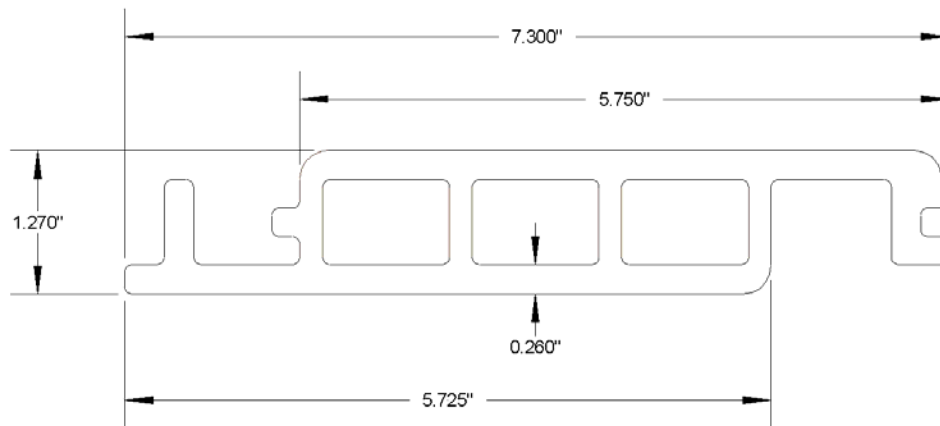
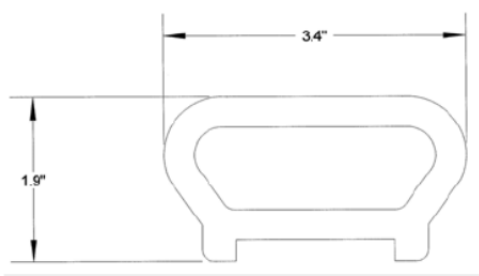
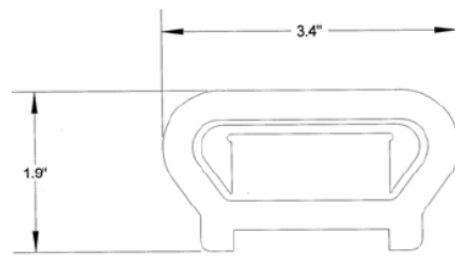

FIGURE 6—DUXXBK™ DECKING 5/4 BY 6 INTERLOCKING BOARD (HOLLOW)



BOTTOM RAIL



TOP RAIL

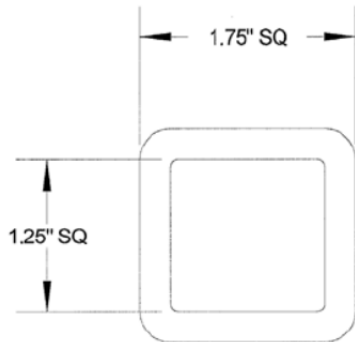

PICKET

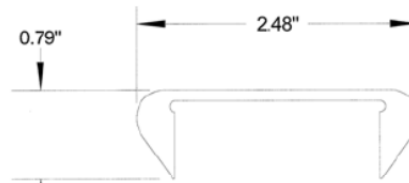

ALUMINUM INSERT FOR TOP RAIL

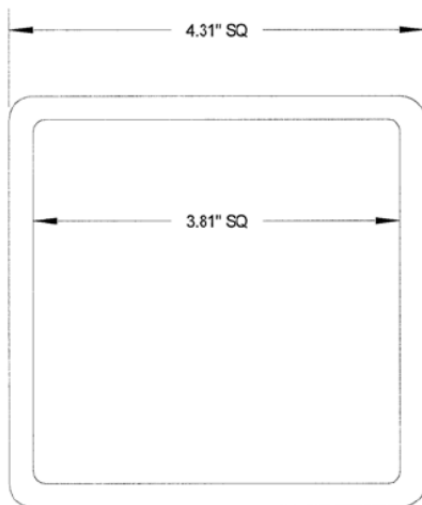

POST SLEEVE



POST SLEEVE

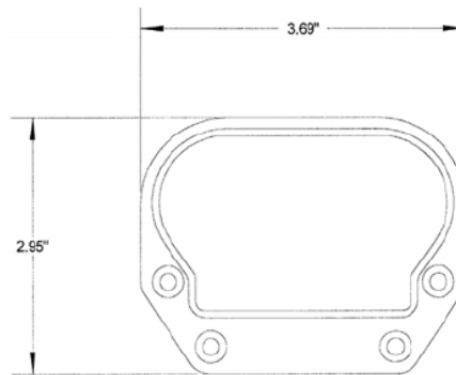

BRACKET COVER

FIGURE 7—GUARDRAIL